



technical manual

ConSensus[®] CPC-02

dual channel pulse counter

Introduction:

The ConSensus CPC-02 is a dual channel pulse counter module designed for the calibration of all sorts of pulse meters. It measures the number of full pulses, and the elapsed time of each input channel individually, whilst synchronizing all inputs to a single master meter.

The CPC-02 communicates through RS485 with either a ConSensus system controller, or a PC through an RS232/RS485 interface.

Applications:

- C calibration of fluids- and gas meters.
- C digital metering.

Features:

- C Precise time measurement of full pulses.
- C Starting and stopping of multiple pulse counters synchronized with selected master meter or with push-button start/stop.
- C 32 bits counters.
- C Wide input voltage range: 5..30V DC.
- C Schmitt trigger inputs.
- C Inputs galvanically insulated from power and communication.
- C Software selectable input threshold voltage, from 2,5V to 15V.
- C Software selectable positive or negative edge.
- C Software selectable pulse fault detection.
- C Software selectable debounce adjustable in steps of 20 μ s.
- C Frequency range up to 10kHz (minimum pulse width 50 μ s).
- C Wide power supply voltage range: 12..24V DC, low power: 3VA max.
- C DIN rail mount, with plug-in Phoenix screw terminals and distribution of power and communication in the rail.

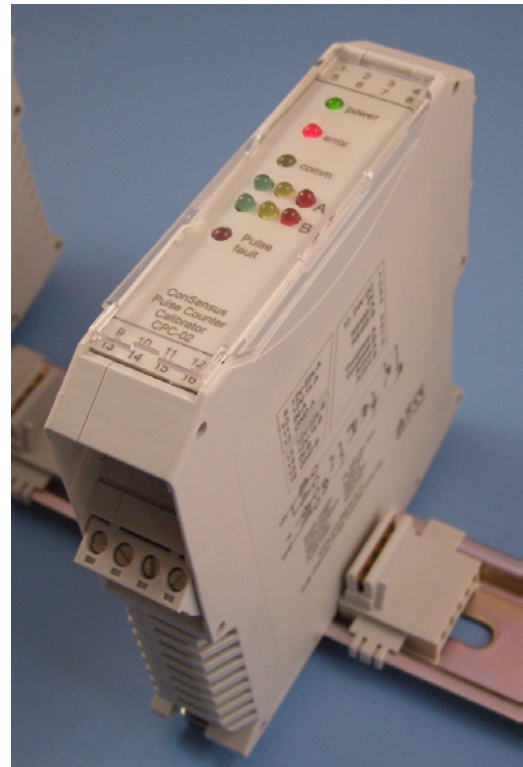

Table of contents:

Introduction:	1
Applications	1
Features	1
General description	3
Glossary	3
Block diagram	3
Theory of operation	4
Pulse fault detection	5
Debouncing of the input signal	6
LED indicators	7
Connecting to pulse generators	8
Input characteristics	8
Power, communication and synchronization connections	9
Connecting to a PC COM port	9
Communication protocol	10
Software	10
Setting the device address	11
Technical specifications	12
Mechanical dimensions	14
Electrostatic warning	15
Disclaimer	15
Contact	15

General description:

Many metering devices generate electric pulses for remote monitoring of the flow or volume. In order to calibrate such meters, their flow is compared to highly accurate standard meters. Basically, the number of pulses of the standard is compared to the number of pulses of the meter under test. Taking the factor of the standard in account, which states how many pulses it gives for a certain volume, the volume of the meter can be calculated, and hence the number of pulses per volume.

For extra accuracy, three features are incorporated in the CPC-02:

- C synchronisation: making sure that the pulses are counted in the same period of time, so that changes in the flow will effect both meters equally.
- C full pulse measurement: if one meter is low frequency, and the other meter is high, it is essential that the calibration system compares a number of full pulses from the slowest meter and compare these with the number of full pulses of the fast meter.
- C for even more accuracy, the elapsed time of every meter can be measured. The CPC-02 has a crystal oscillator for high accuracy, and distributes a single timebase amongst all CPC-02 modules, so that any deviation will automatically be cancelled out.

Glossary:

- Standard: high precision meter, typically high-frequency pulse output.
Meter: meter under test.
Master: input that determines the start and stop of the measurement, typically the one with the lowest frequency (meter under test), or manual push-button switch.

Block diagram:

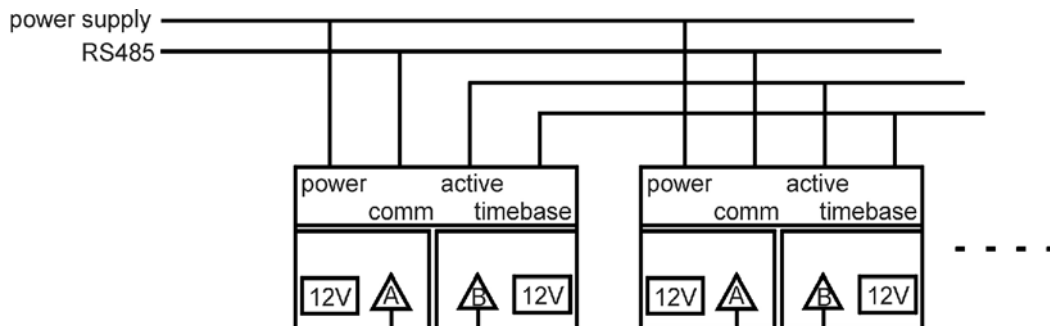

Each CPC-02 features galvanic isolation barriers for both inputs, to electrically separate them from each other, and from the power supply and communication. These barriers consist of fast opto-couplers to pass signals from input to output, and DC/DC convertors to pass the auxiliary power to the input circuitries.

A minimum pulse counting system consists of a single CPC-02, a DC power supply and a controller such as a PC with RS485 adapter, or a ConSensus system controller. If more pulse counting inputs are required, up to 31 CPC-02's can be connected in parallel. One of these CPC-02's will provide a timebase to all other CPC-02's, to ensure that all time measurements use the same clock to cancel out deviations. Moreover, the CPC-02 that has the 'master' meter connected will control the Active signal, to synchronise the starting and stopping of the measurement in all the other CPC-02's.

Theory of operation:

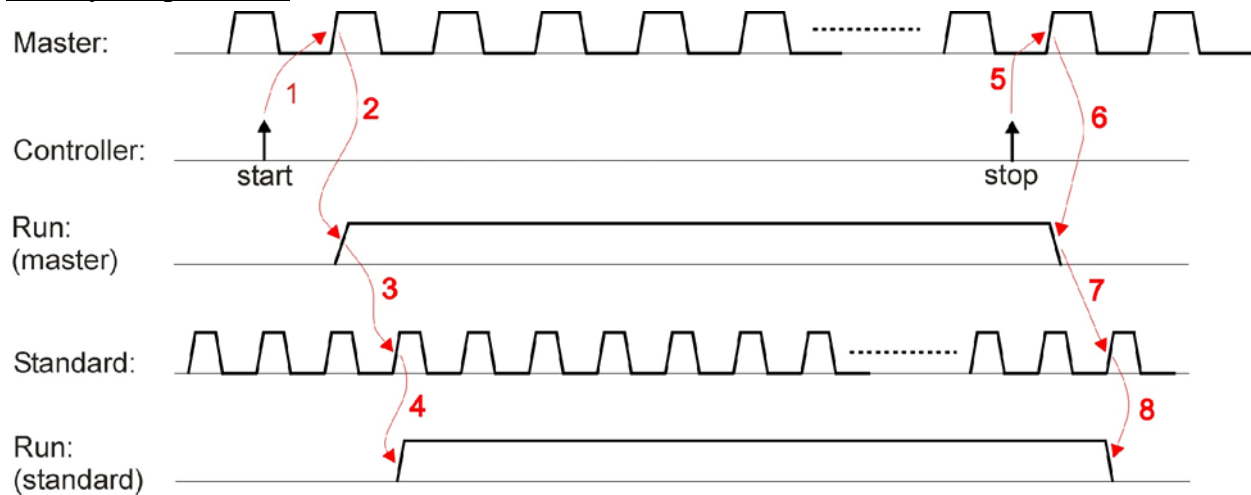

- 1: the system controller (PC or ConSensus controller) issues a start command over the RS485 communication bus. This start command is received by the CPC-02 that has the master function. The master input awaits the first valid pulse edge before starting the actual measurement, to ensure that only full pulses are counted and timed.
- 2: the first valid edge occurs, the master enters RUN state and starts the high resolution timer for this input. The yellow RUN led is lit, and the master activates the ACTIVE output to signal to all other CPC-02's that the measurement has started.
- 3: all other inputs wait for ACTIVE to become active, and then wait for the next valid edge of their pulse inputs. In this example, the input for the high frequency standard meter has to wait almost a full pulse time before detecting the first valid edge.
- 4: the input has detected the first valid edge after ACTIVE became active, and enters RUN state as well, starting its corresponding high resolution timer.
- 5: the system controller issues a stop command. The master input waits until the first valid edge before stopping the measurement, to ensure that only full pulses are counted and timed.
- 6: the valid edge after stop has occurred. The master exits RUN state and stops the high resolution timer for this input. The yellow RUN led is turned off, and the master deactivates ACTIVE.
- 7: other CPC-02 inputs detect that ACTIVE is no longer active, but stay in RUN state until their first valid edge, to also measure the time of full pulses.
- 8: the input has detected the first valid edge after ACTIVE deactivates, exits RUN state and stops its high resolution timer.

Pulse fault detection:

Certain meters are equipped with dual sensors on the same shaft, generating pulses that are phase shifted by 90 degrees. Such sensors are typically used for quadrature modulation, to detect the direction of the flow.

The CPC-02 is featured with a programmable missing pulse detector, that can issue a fault signal when one of its inputs detects two consecutive pulses without detecting a pulse on the other input:

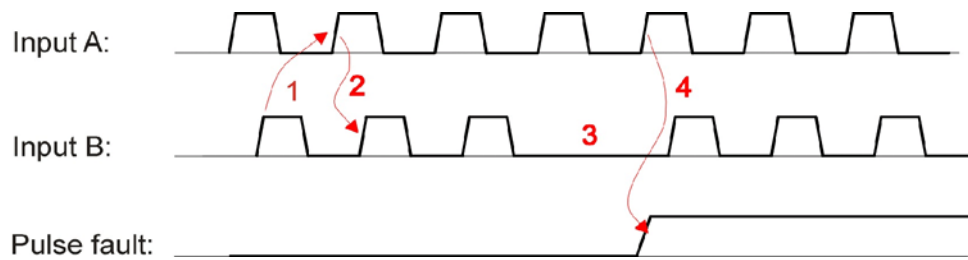

- 1: the pulse on input B is followed by a pulse on input A.
- 2: the pulse on input A is followed by a pulse on input B. This is the normal situation.
- 3: sensor B misses one pulse.
- 4: Input A detects a pulse, without input B having detected a pulse since the previous pulse on A. The pulse fault is issued.

The “pulse fault” detector can be enabled, reset and disabled by a command over the RS485 bus. If pulse fault detection is enabled, and a fault is detected, the fault is signaled visually by the led “P-fault” and to the master through a status flag over the RS485 bus.

Please note that pulse fault detection requires both signals to be connected to the same CPC-02.

Debouncing of the input signal:

If the input signals are low frequency and noisy, a digital filter can be programmed to reduce counting of false pulses. This is especially important when the input is a manual switch or electromechanical contact, or an optical detector.

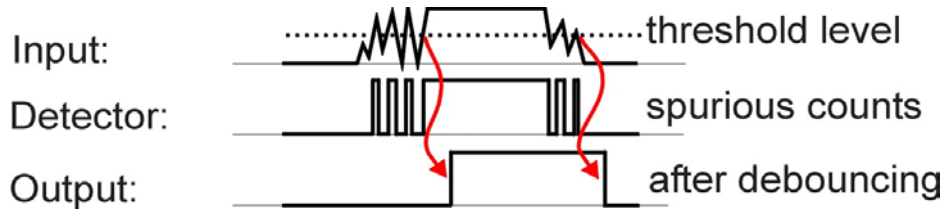

The noisy input signal in this example passes the threshold level several times before becoming stable, causing the detector to count several pulses (6 pulses instead of 1).

The filter, called debouncer, has the effect of delaying the detection until the input has been stable for a certain period of time.

It can be programmed in steps of 20 μ s from 0 to 50000 (1 second).

Logically, debouncing reduces the maximum input frequency and increases the minimum pulse duration. As a rule of thumb, use following debounce values:

Application	Debounce value	Debounce time	maximum frequency
HF meter	0	0 μ s	10 kHz
HF meter	4	80 μ s	2000 Hz
LF meter	100	2 ms	100 Hz
Optical detector	1000	20 ms	10 Hz
Manual push button	2500	50 ms	5 Hz

Note: values given are valid for pulses of approximately 50% duty cycle. If pulses have a larger or smaller duty cycle, the debouncer should be reduced accordingly, to ensure detection of short pulses or short pauses.

LED indicators:

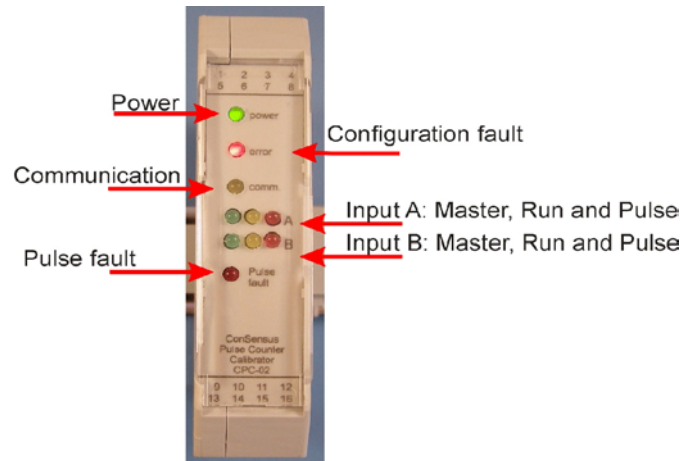

LED	color	function
Power	green	Steady: power is OK, system is running. Interrupted: power is low, or internal failure.
Configuration fault	red	Device has been powered on, but not yet received its configuration data from the master. Alternatively this led will indicate if no timebase master is present in the system.
Comm	yellow	Indicates communication with PC or system controller.
Master	green	Signals that this particular input is used to start and stop the measurement in all CPC-02's. Typically, it is the slowest meter in the system, or a push-button.
Run	yellow	Measurement has started, and the first valid pulse edge has been detected. The input starts counting and the timer is started for this input. Switches off when the measurement is stopped, but only after the next valid pulse edge is detected.
Pulse	red	Switches on when a valid pulse edge is detected, and switches off when the opposite edge is detected.
Pulse fault	red	If pulse fault detection is enabled, this led will indicate when two A pulses are detected without B pulse, or when two B pulses are detected without A pulse. Only used for meters with dual pick-up sensors and/or quadrature sensors.

At power-up, all eight LEDs will be lit for about 1 second.

Connecting to pulse generators:

Input characteristics:

Each input of the CPC-02 consists of a 10 kohm resistor, followed by protection circuitry and an amplifier. Under normal operating conditions, the input impedance is 12 kohm. The CPC-02 can detect pulses of 50µs minimum pulse width. The input range is 5V to 30V positive from GND.

The trigger level at which input pulses are detected is programmable from 2.5V to 15V.

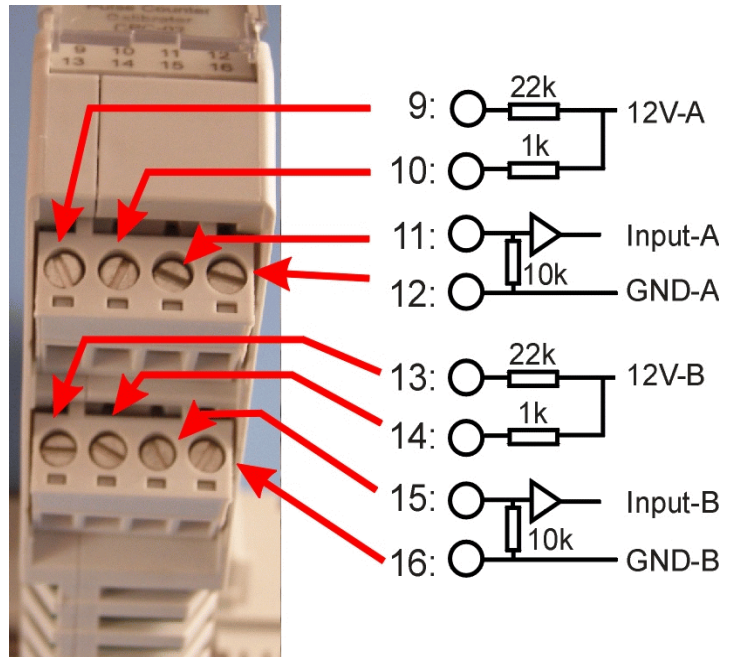

application:	recommended threshold level
TTL or CMOS pulse	2.5V
contact connected to 12V-1k	6.0V
24V sensor	12.0V

The input circuitry is equipped with Schmitt trigger inputs, whose hysteresis suppresses jitter when the input voltage is around the threshold voltage. Nevertheless, it is strongly recommended to ensure that the input pulses are digital pulses with fast rise and fall times, and to set the threshold to approximately half the peak input voltage.

Pins 9 and 13 have an internal 22k resistor to 12V, and can be used to supply 0,5mA to an optical detector (NPN transistor). Pins 10 and 14 have a 1k resistor to 12V, that can be used to supply 10mA to the LED of an optical detector, or to supply more current to the detector output.

Power, communication and synchronization connections:

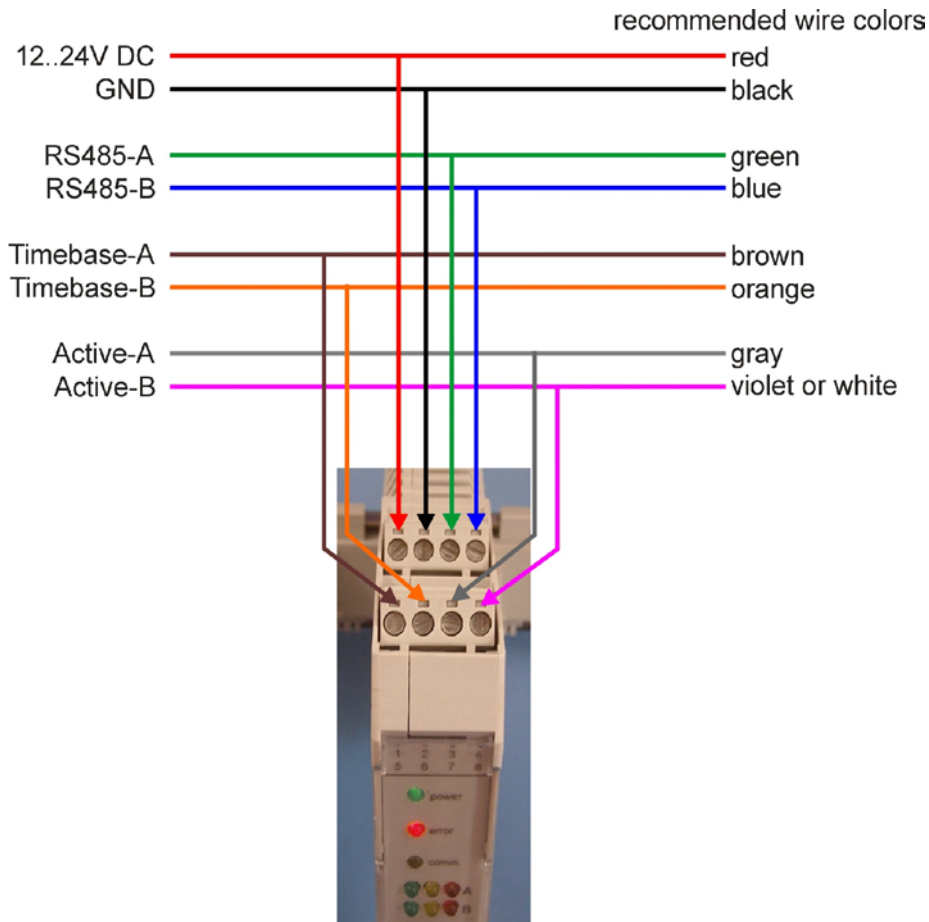

Note: if the wire length between devices is longer than just a few centimeters, it is strongly recommended to use twisted pair wire for each of the wire pairs RS485 A/B, Timebase A/B and Active A/B.

Connecting to a PC COM port:

If the CPC-02 system is to be controlled by a PC, a convertor is required to convert the COM port RS232 signals to RS485.

Most suitable is the Spectra USB to RS485 adapter, available from Exatech bv.

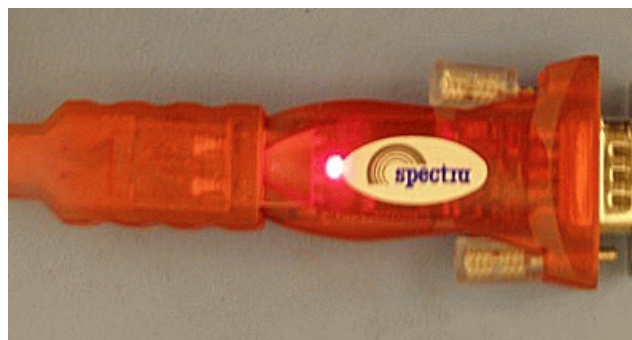

Communication protocol:

The CPC-02 communicates at 115200 baud, 8 bits, 2 stop bits, odd parity. The device acts as a slave on the bus, replying to commands that address the device uniquely.

Data and commands are exchanged in frames that contain the device address of the destination device, and of the source device, typically the master (PC or controller). Each data byte is error checked using the parity bit, and the total frame is error checked using a cyclic redundancy check (CRC-16). The contents of the frames is an Exatech bv proprietary protocol. Optionally, Modbus RTU protocol is available.

As RS485 is half duplex, only one transmitter can be active at any time. Typically the PC or controller initiates a communication cycle, inviting the slave device to return a reply. The PC must disable its RS485 transmitter immediately after the last byte of the frame has been transmitted, or at least within 500µs. Windows PC's cannot meet this requirement, and need an intelligent convertor such as the Spectra USB-RS485 adapter.

Some of the commands supported are:

- Set configuration: transfer A-debounce, A-threshold, A-edge, B-debounce, B-threshold, B-edge and master selections.
- Start/stop: start and stop a measurement at the master meter
- Reset: clear last results and stop any on-going measurement.
- Read status: read A-frequency, A-pulsecount, A-elapsetime, B-frequency, B-pulsecount and B-elapsetime.

The application software must make sure that only one timebase master in the system is active at any one time, and only one input is assigned as Master.

Software:

For more information about the ConSensus Pulse Calibration software package, please refer to the software documentation.

Setting the device address:

Each ConSensus device should be assigned a unique address on the RS485 communication bus. The ConSensus devices have no dipswitches or keyboard through which a number can be entered. There is however a single push button, accessible from the side. The PC software will transmit a device address during 30 seconds, and when the switch is operated at one of the ConSensus devices, this device will accept and store the device address, and use it from then on. To use this program feature:

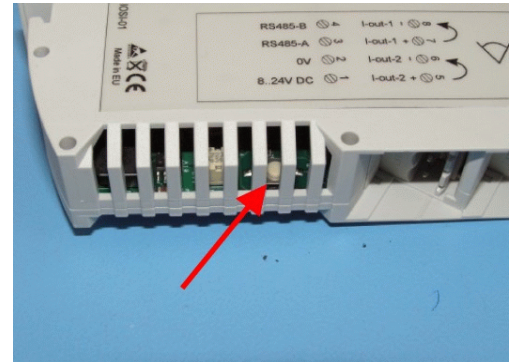

- C open File / Settings / Device list.
- C A screen will open that shows a list of all 31 possible ConSensus devices connected to the bus. Select an empty box and enter the type of device. In this example, we will make device number 10 a CMA.
- C Click the ‘binoculars’ button in box 10 to locate this device.
- C If necessary, change the device address, but usually the address will be the same as the box number.
- C click OK: this will start a special sequence in which the device is requested to accept the number.

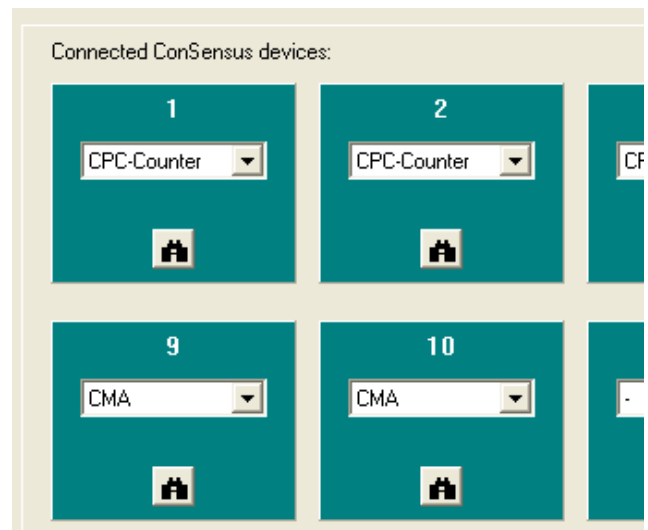

- C At the device, press a non-conductive (plastic) pin through the little hole above the Power led to operate the miniature switch. After about one second the device will start to communicate and the “Change device address” window on screen closes.

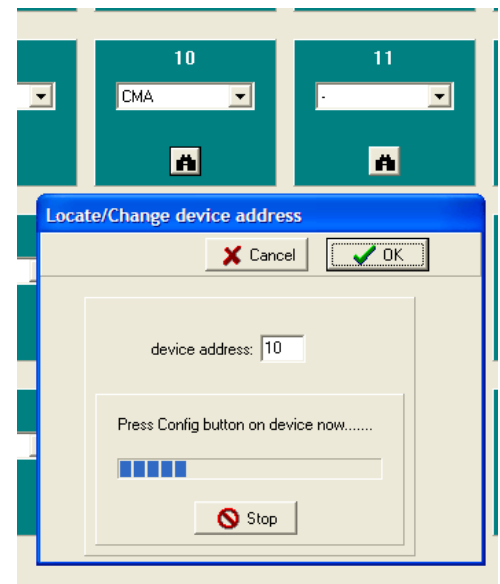

Technical specifications:

Parameter	Min	Typ	Max	Unit
Input voltage (inputs A and B):	5		30	V DC
input frequency (note 1):	0.1Hz		10	kHz
input pulse width:	50		-	µs
input impedance	10	12	12.5	kohm
Timebase frequency	51.15	51.200	51.25	kHz
Frequency measurement accuracy		1		%
Pulsecount measurement accuracy		1		pulse
Time measurement resolution		20		µs
Time measurement accuracy		0.01		%
Measurement time			10	hours
Power supply:	12		24	VDC
power consumption:	1		3	VA
Input DC/DC power supplies:	11.5	12.0	12.5	V DC
Communication wire length			100	m
number of devices on a single bus line			31	
wire diameter (solid)	0.5		4	mm ²
Environment temperature	0		55	EC
humidity	10		85	%
protection		IP40		

Note 1: CPC-02 is designed as a pulse-counter, and is not a frequency meter. It estimates the input frequency from the number of pulses per second. At very low frequencies pulses will be counted and timed correctly, but the frequency indication will be incorrect: the frequency measurement of the CPC-02 will wait for a maximum of 10 seconds for the next pulse, and if this does not occur, it will output the period

time since the last pulse. The frequency will appear to ‘jump’ to 0.1 Hz, and then slowly decrease:

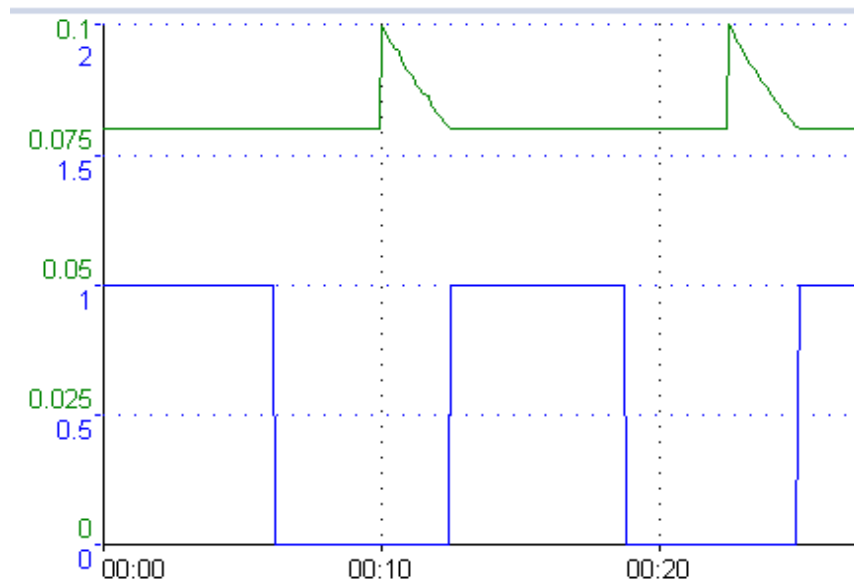

Green is the frequency, blue is the pulse at 0.09Hz.

This behaviour is intentional, and without this, a sudden disappearance of pulses would not be visible for a very long time.

Mechanical dimensions:

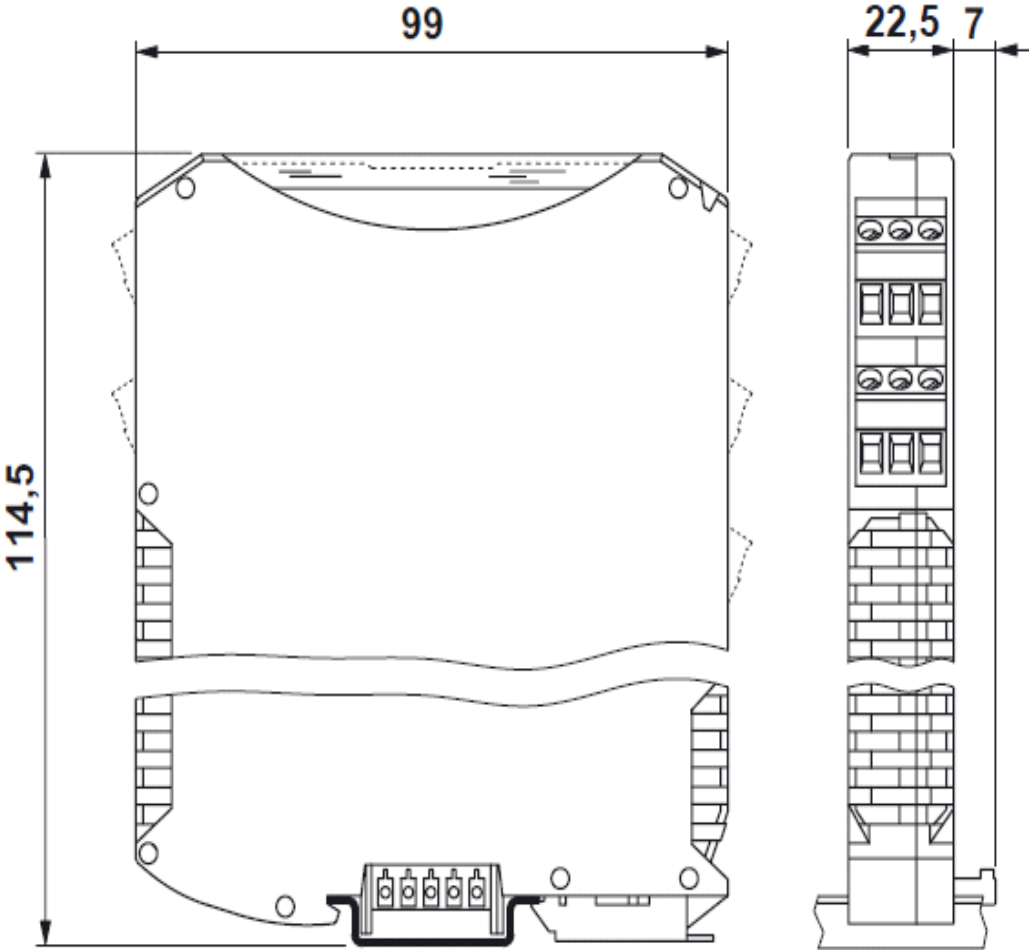

Electrostatic warning:

The CPC-02 is equipped with internal anti-static protections. Nevertheless, the device should not be subjected to high electrostatic potentials. A grounding strap or similar protective device is strongly recommended when handling or connecting the device. Avoid touching the connections or any other metallic element.

Disclaimer:

Information furnished is believed to be accurate and reliable. However, Exatech bv assumes no responsibility for the consequences of use of such information nor for any infringement of patents or other rights of third parties which may result from its use. No license is granted by implication or otherwise under any patent or patent rights of Exatech bv. Specifications mentioned in this publication are subject to change without notice. This publication supersedes and replaces all information previously supplied. Exatech bv products are not authorized for use as critical components in life support devices or systems without express written approval of Exatech bv.

Trademark:

ConSensus[®] is a registered trademark of Exatech bv.

Contact:

For more information about the ConSensus systems, or for development of special modules and software, please contact:

Exatech bv
Singel Albert Cuyp 285
3311 HD Dordrecht
The Netherlands

tel.: +31-78-6148792
email: info@exatech.nl
websites: www.exatech.nl
www.consensus.nl